

1x



2x



2x



www.elotouch.com

Quick Installation Guide

Status Light Kit

Revision A
P/N E656363

Elo Touch Solutions Technical Support

Online self-help:
www.elotouch.com/support

North America

800-ELO-TOUCH
Tel +1 408 597 8000
Fax +1 408 597 8050
EloSales.NA@elotouch.com

Europe

Tel +32 (0)16 70 45 00
Fax +32 (0)16 70 45 49
elosales@elotouch.com

Asia-Pacific

Tel +86 (21) 3329 1385
Fax +86 (21) 3329 1400
EloAsia@elotouch.com

Latin America

Tel +52 55 2281-6958
EloSales.LATAM@elotouch.com

The information in this document is subject to change without notice. Elo Touch Solutions, Inc. and its Affiliates (collectively "Elo") makes no representations or warranties with respect to the contents herein, and specifically disclaims any implied warranties of merchantability or fitness for a particular purpose. Elo reserves the right to revise this publication and to make changes from time to time in the content hereof without obligation of Elo to notify any person of such revisions or changes.

No part of this publication may be reproduced, transmitted, transcribed, stored in a retrieval system, or translated into any language or computer language, in any form or by any means, including, but not limited to, electronic, magnetic, optical, chemical, manual, or otherwise without prior written permission of Elo Touch Solutions, Inc.

Elo (logo) and Elo Touch Solutions are trademarks of Elo and its Affiliates.

© 2018 Elo Touch Solutions, Inc. All rights reserved.



Installation

1

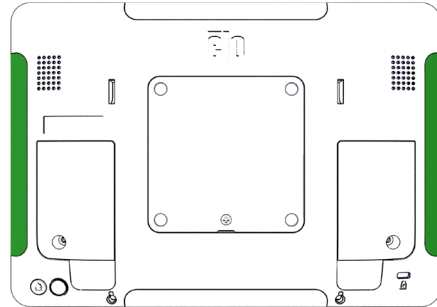

Remove the Edge Connect peripheral covers to expose the peripheral bay. Up to two status lights can be installed on a single I-Series display

2

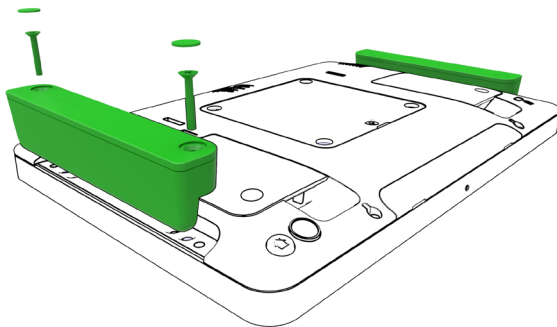

Gently press the status light into the Edge Connect peripheral bay making sure the connector is seated. Then install the included screws and screw covers.

Note: This kit is only compatible with I-Series "Standard" version. Status light Kit P/N E51272 is compatible with I-Series "Value" versions.

3

Go to elotouch.com/support to download device drivers and software development kit for this device.

1x



2x



2x



2x Cables (1 long and 1 short)
(Value version only)

Elo Touch Solutions Technical Support

Online self-help:
www.elotouch.com/support

North America

800-ELO-TOUCH
Tel +1 408 597 8000
Fax +1 408 597 8050
EloSales.NA@elotouch.com

Europe

Tel +32 (0)16 70 45 00
Fax +32 (0)16 70 45 49
elosales@elotouch.com

Asia-Pacific

Tel +86 (21) 3329 1385
Fax +86 (21) 3329 1400
EloAsia@elotouch.com

Latin America

Tel +52 55 2281-6958
EloSales.LATAM@elotouch.com

The information in this document is subject to change without notice. Elo Touch Solutions, Inc. and its Affiliates (collectively "Elo") makes no representations or warranties with respect to the contents herein, and specifically disclaims any implied warranties of merchantability or fitness for a particular purpose. Elo reserves the right to revise this publication and to make changes from time to time in the content hereof without obligation of Elo to notify any person of such revisions or changes.

No part of this publication may be reproduced, transmitted, transcribed, stored in a retrieval system, or translated into any language or computer language, in any form or by any means, including, but not limited to, electronic, magnetic, optical, chemical, manual, or otherwise without prior written permission of Elo Touch Solutions, Inc.

Elo (logo) and Elo Touch Solutions are trademarks of Elo and its Affiliates.

© 2018 Elo Touch Solutions, Inc. All rights reserved.



www.elotouch.com

Quick Installation Guide

Status Light Kit

Revision A
P/N E656560

Installation

1

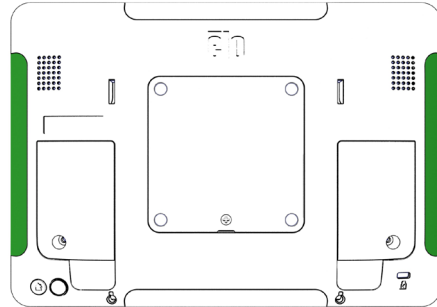

Remove the Edge Connect peripheral covers to expose the mounting interface. Up to two status lights can be installed on a single I-Series display

2

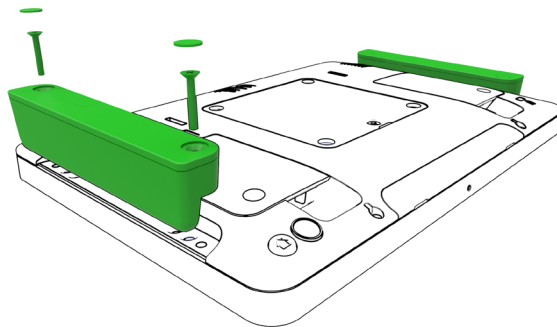

Fasten the status light to the I-Series using the included screws and screw covers.

3

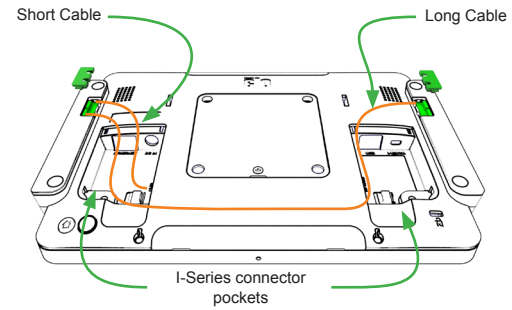

Remove the connector covers from each status light and connect the GPIO cables as shown. Use the short cable to connect the nearest light to the I-Series GPIO connector. Use the long cable to connect a second light to the first light. Then reinstall the connector covers making sure the cables route through the openings in the covers and are not pinched.

Extra cable length can be coiled up and stored in either of the I-Series connector pockets.

4

Go to elotouch.com/support to download device drivers and software development kit for this device.