



## NE150

Any tablet. Always connected.  
Instant mobility.



### MIX-&-MATCH

Supports Honeywell's EDA10 and future Honeywell USB-C tablets.

### RELIABLE CONNECTION

High-speed USB 3.0 data port supports a wide range of peripherals.

### SIMPLE SOLUTION

Cost-effective, compact tablet stand that easily converts from a fixed to mobile solution.



### OVERVIEW

NE150 is a sleek, small-scale tablet stand designed to meet business needs at a budget-friendly price. Integrated charging, USB 3.0 high-speed data connectivity, and detachable handle supports peripherals and transitions from a fixed solution to portable handheld for an agile in-store experience.

### FEATURES AND BENEFITS

- 1 Fits Honeywell EDA10 tablet and future Honeywell USB-C tablets up to 13"
- 2 Compatible with Android and Windows
- 3 High-speed data port supports up to 5Gbps
- 4 USB-C port connection for peripherals
- 5 Tilt/flip tablet screen from associate to customer
- 6 Detachable handle for instant mobility that serves as a secondary stand
- 7 Integrated charger with built-in LED indicator lights



## FEATURES AND BENEFITS *(continued)*

- 1 Built-in cable management in the base hides unsightly wires or routes them to a single side
- 2 Base can be affixed using non-slip adhesive or bolt mounted
- 3 Handle locks to base for a fixed stand solution
- 4 Compatible with all NE360C payment cradles when used with adapter cable (optional)

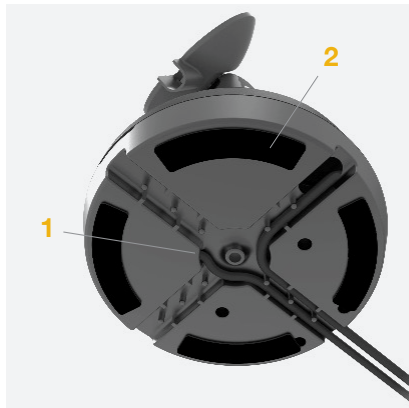

## CORE APPLICATIONS

- Point of sale
- Registration processes
- Self check-in/checkout
- Endless aisle
- Clienteling
- Product comparisons
- Line busting
- Inventory audits
- Restaurant menu displays/ order kiosk
- Ticketing
- Payment processing

©2024 InVue Security Products. No endorsement of InVue products has been made by any of the manufacturers of the products shown. Product is sold pursuant to InVue's warranty which can be found at [invue.com/warranty](http://invue.com/warranty).

